

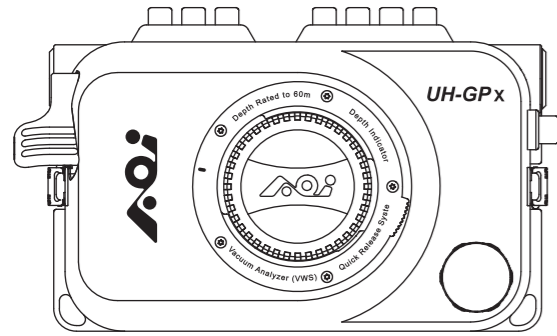

AOI UH-GPx UNDERWATER HOUSING

GENERAL GUIDE



Thank you for your purchase of an AOI product. Please read this general guide prior to using the housing. It will provide an overview of how this product can be used for optimal performance. For additional information, please consult your local dealer or write to info@aoi-uw.com

Items Included in the Package

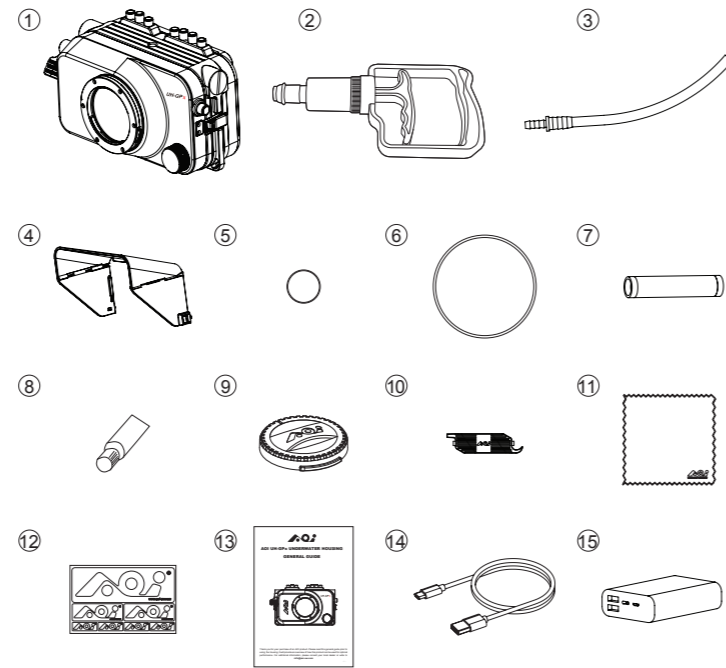

- ① AOI UH-GPx Housing
- ② Vacuum Pump (AOI VP-02)
- ③ Vacuum Pump Extension Hose
- ④ Camera Display Shade (AOI LCDH-02)
- ⑤ Spare O-Ring for Vacuum Valve
- ⑥ Spare Main Seal O-Ring x 1pc.
- ⑦ Moisture Muncher Capsules™ x 1pc.
- ⑧ Silicone Grease (AOI SIGR-5)
- ⑨ Lens Port Front Cap
- ⑩ O-ring Remover (AOI ORR-02)
- ⑪ Micro-Fiber Cleaning Cloth (AOI MC-01)
- ⑫ AOI Logo Sticker
- ⑬ General Guide
- ⑭ USB Type-C Charging Cable
- ⑮ Power Bank
- ⑯ Depth Sensor
- ⑰ Main Power Button
- ⑱ Select Button
- ⑲ Brightness Control Button
- ⑳ Status Display
- ㉑ Power / Alert Indicator
- ㉒ Security Lock for Shutter Release Lever

Parts Name

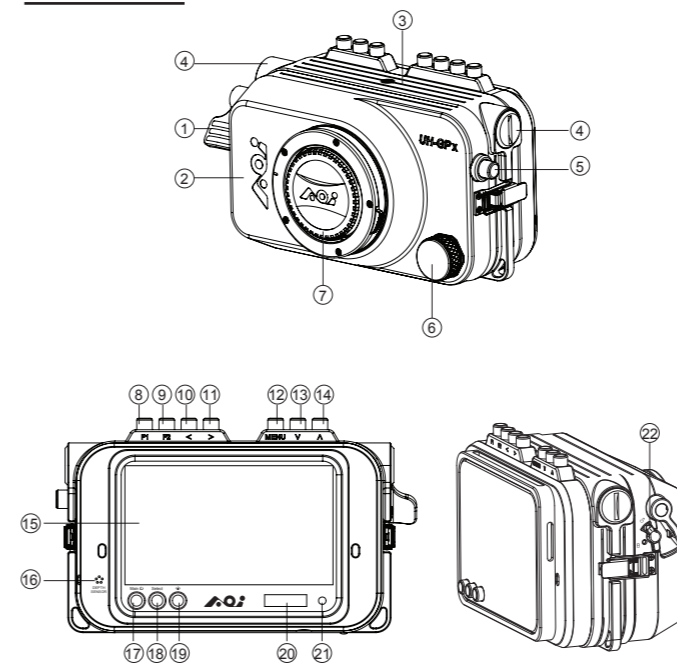

- ① Shutter Release Lever for Camera
- ② Front Cover
- ③ Housing Body
- ④ Handle Extension Port Cap
- ⑤ Mode Button for Camera
- ⑥ Vacuum Valve
- ⑦ Lens Port Front Cap
- ⑧ F1 Button
- ⑨ F2 Button
- ⑩ < Left Button
- ⑪ > Right Button
- ⑫ MENU Button
- ⑬ V Down Button
- ⑭ ^ Up Button
- ⑮ Camera Display
- ⑯ Depth Sensor
- ⑰ Main Power Button
- ⑱ Select Button
- ⑲ Brightness Control Button
- ⑳ Status Display
- ㉑ Power / Alert Indicator
- ㉒ Security Lock for Shutter Release Lever

Opening UH-GPx Front Cover

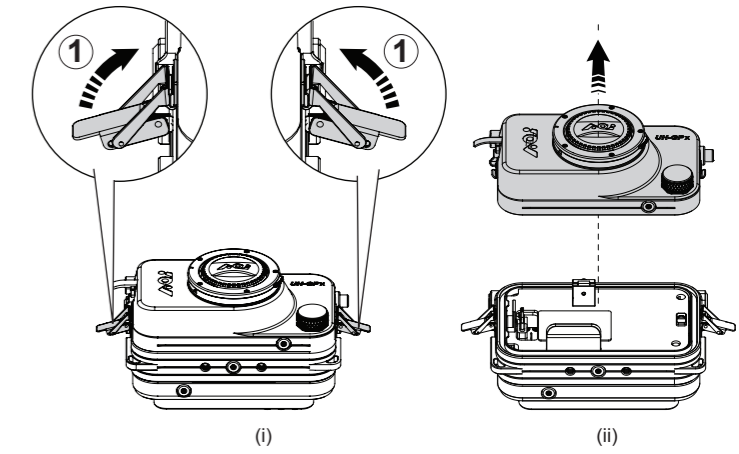

Installing Power Bank

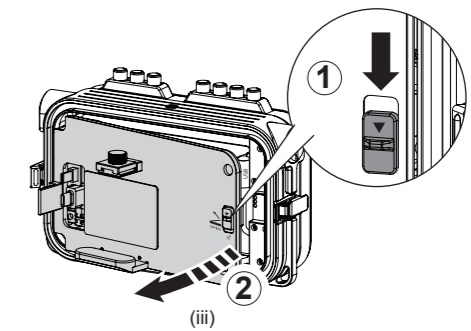

Video of Installing Power Bank

- 1 -

- 2 -

- 3 -

- 4 -

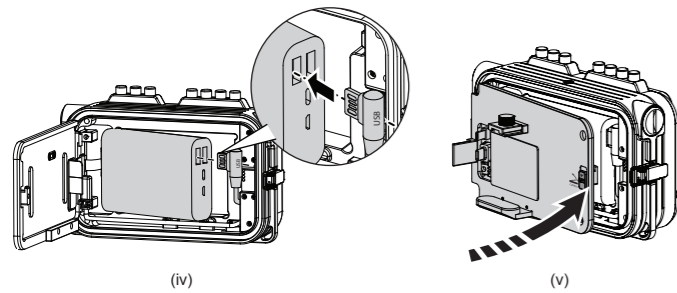

Installing GoPro Camera to Media Mod

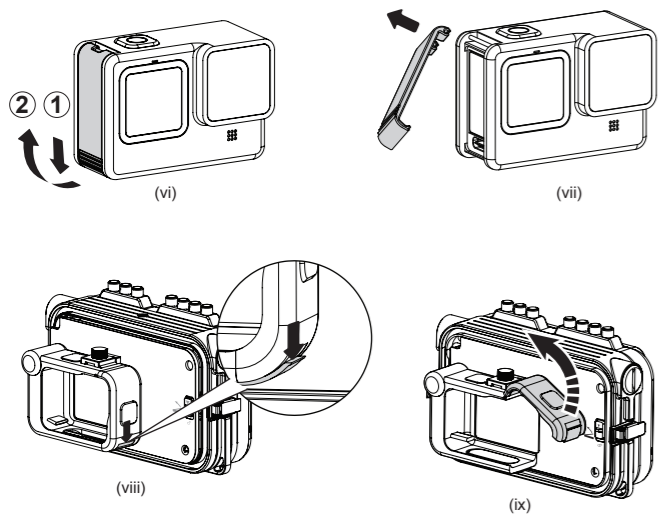

Video of Installing GoPro Camera to Media Mod

- 5 -

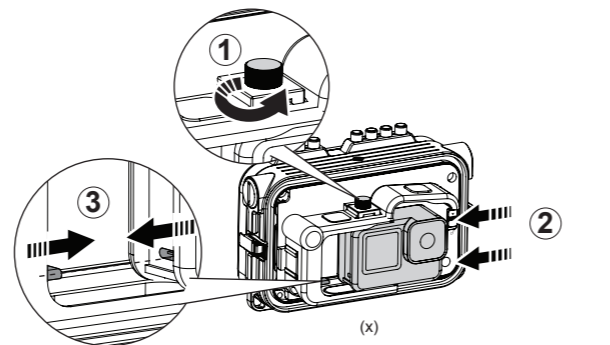

Closing UH-GPx Front Cover

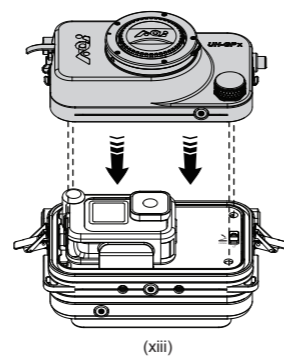

- 6 -

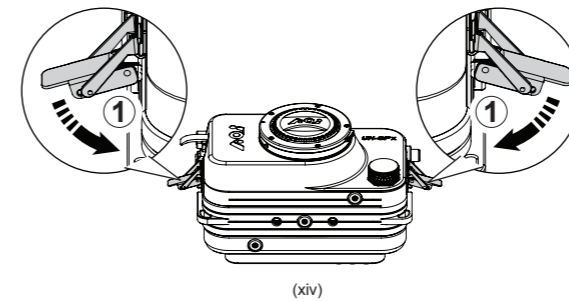

Installing Camera Display Shade

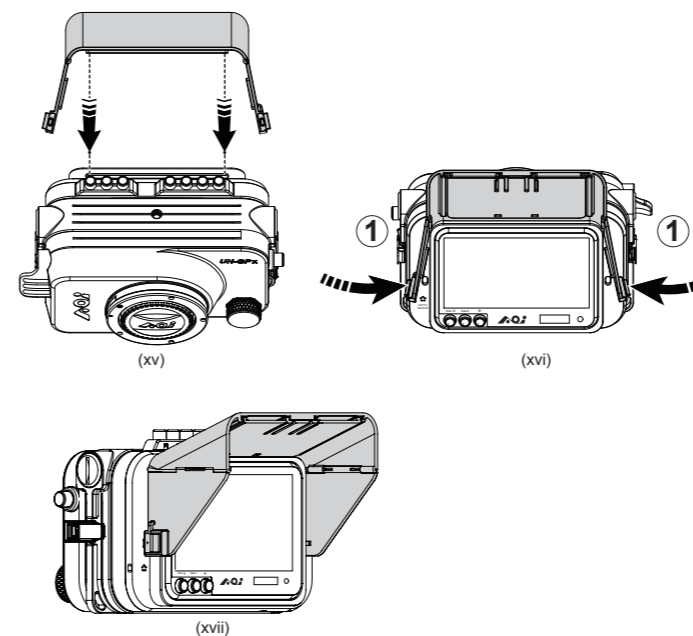

How to maintain the housing

- a. Rinse the housing exterior thoroughly with running fresh water after every use. Depress buttons and rotate knobs/dials repeatedly in fresh water to eliminate trapped salt water or debris. Dry the housing and Lens Port with a soft, clean cloth to avoid water spotting and damage.
- b. To clean the Lens Port Glass, use a mild soap solution or lens cleaner. Do not rinse the inside of port glass. Do not use alcohol or window cleaner on the Lens Port Glass. In order to better inspect, position, clean or lubricate the Housing Main Seal O-ring, carefully remove the required O-ring by using the provided AOI O-Ring Remover.
- c. Clean the Main Seal O-ring and its O-ring groove by using a microfiber cloth only. Use AOI O-Ring Remover to clean the O-Ring groove. Do not use cleaning substances other than fresh water. Remove sand, dirt, hair or fibers that can prevent a proper housing seal.
- d. To lubricate O-rings, apply a small amount of silicone grease (AOI SIGR-5) on your fingertips, gently pull the O-ring through the fingertips. This will lightly coat the entire O-ring with silicone grease. Only use the AOI Silicone Grease supplied or those approved by AOI. Using other brands of silicone grease may damage the O-ring. Do not over stretch the O-ring.
- e. Do not leave the camera and housing in direct sunlight for prolonged periods. Heat may damage the camera and housing.
- f. Dry well and remove the camera prior to travel and storage.
- g. Store the housing in a cool and dry place.

IMPORTANT:

- a. Wipe the housing dry and keep water away prior to opening the housing. Do not allow water to be in contact with the interior of the housing. This will cause irreparable damage to the Vacuum Analyzation and Wet Detection System (VWS) and other electronic/electrical components!
- b. When not using the housing, remove the Power Bank.
- c. Do Not flush the holes of the Depth Sensor with High-Pressure water.

- 7 -

- 8 -

Status Display Operation Flow Chart

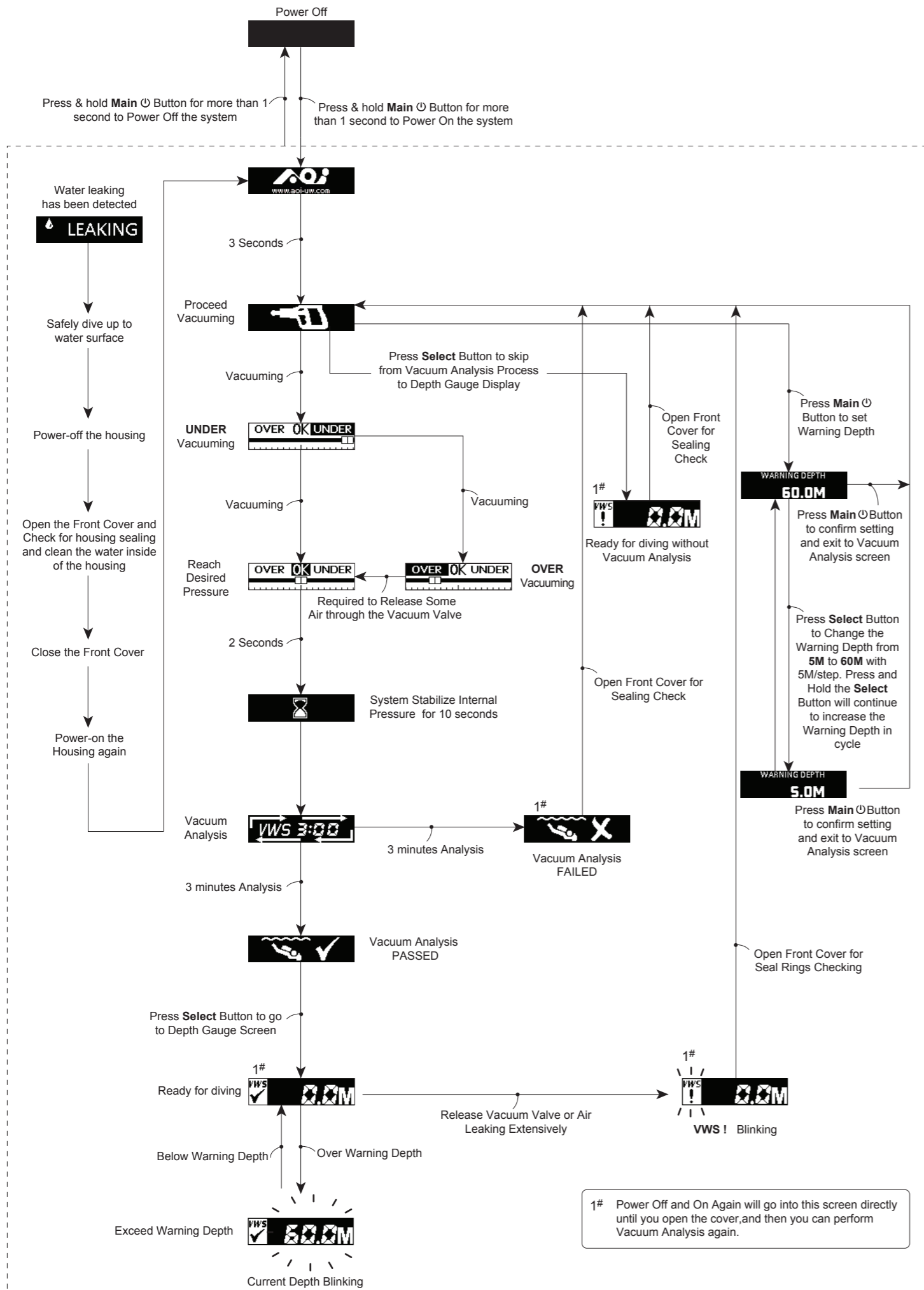

Status Display Brightness Control & Camera Display On/Off

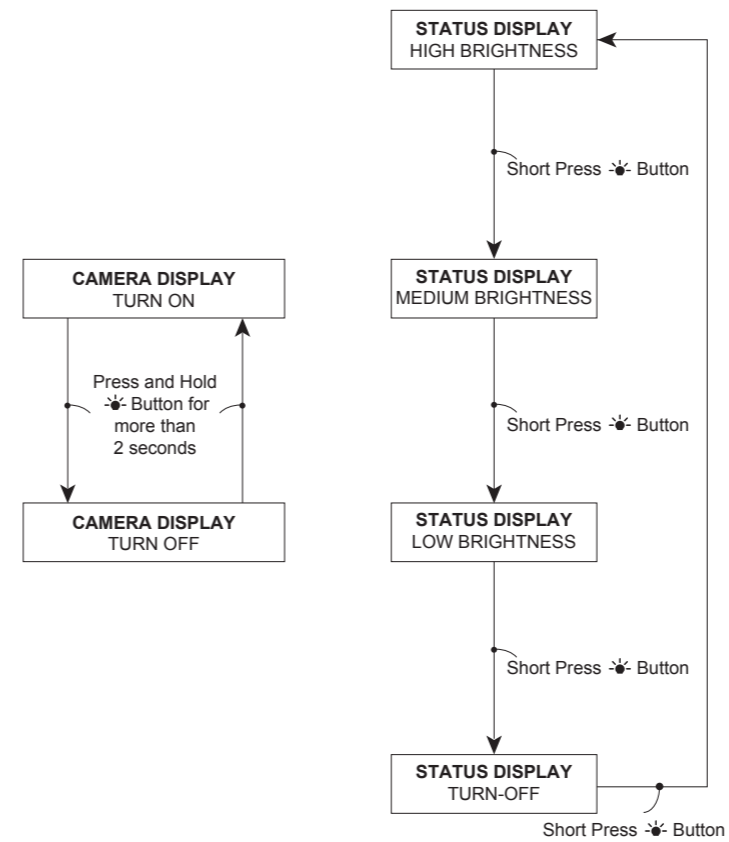

Status Display Description

STATUS DISPLAY	DESCRIPTION
	a) Main Button has been Turned-on. b) Greeting Front Page
	Perform Vacuuming
	Internal Pressure Reach Desired Pressure and Stop Vacuuming
	Internal Pressure is Higher than Desired Pressure and Required to continue vacuuming
	Internal Pressure is Lower than Desired Pressure and Required to Release Some Air through the Vacuum Valve
	Stabilizing Internal Pressure for 10 seconds
	Vacuum Analysis in Progress with Count-down Clock
	PASSED in the Vacuum Analyzation Process
	FAILED in the Vacuum Analyzation Process
	a) Vacuum Analysation and Wet Detection System is working OK b) Display Current Water Depth
	Vacuum Analysation is skipped and Wet Detection System is still in working
	Pre-set the Warning Depth
	Wet Sensor has Detected Water Droplets and / or Heavy Moisture inside the Housing
	Current Water Depth has Reached to the Pre-set Warning Depth (Current Depth Blinking)
	The Housing is Severely Leaking or its Vacuum has been Released (WWS ! in Blinking)

Setting up Camera Display

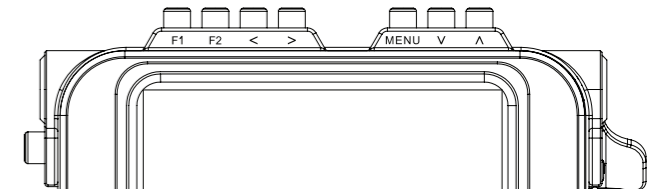

Button	Function when menu is not displayed	Function when menu is displayed
F1	F1 Custom button	/
F2	F2 Custom button	/
^ Up	/	Select previous menu item
v Down	/	Select next menu item
MENU	Display Main menu	Exit current menu
< Left	/	Decrease or adjust value of selected parameter
> Right	/	Increase or adjust value of selected parameter

Specifications

MODEL NO.	AOI UH-GPx
DESCRIPTION	Underwater Housing for GoPro HERO Cameras
COMPATIBILITY	GoPro HERO12, 11, 10 and 9
DEPTH RATING	60 Meters
BODY MAIN MATERIAL	Marine Grade Aluminum Alloy
SURFACE FINISHING	Hardcoat Type III Anodizing
MAIN BODY COLOR	Anodize Flat Black
LENS PORT MOUNT & FILTER SLOT	AOI Quick Release System (QRS) - QR2 Mount with Color Filter Slot
LENS PORT GLASS	Multi-layers AR and Hydrophobic Coating
WATER LEAKAGE PROTECTION	Built-in Vacuum Analyzation & Water Detection System (WWS)
BUILT-IN WATER DEPTH MONITOR	Max. Monitoring Depth up to 60 Meters with Preset Depth Alarm Function
BUILT-IN DISPLAY MONITOR	5" Full HD (1920x1080 pixels) 16:9 Display Monitor
	Viewing Angle 80° / 80° (L/R & U/D)
	High Brightness 400 cd/m ² and Contrast 1000:1
	Focus Peaking Assist
POWER SUPPLY (FOR GOPRO CAMERA, DISPLAY MONITOR, DEPTH MONITOR & WWS)	Digital Zoom (4x, 9x, 16x) Assist
	RGB Histogram, Waveform, Vector Scope & Monochrome ...etc. Functions
	Two Custom-setting Buttons (F1 & F2)
MAIN BODY DIMENSIONS	Removable Power Bank (22.5W, 10,000mAh)
MAIN BODY WEIGHT (INCL.: HOUSING BODY, POWER BANK, MEDIA MOD, CAMERA, CAMERA BATT.)	Operation Time: 2 Hours 30 minutes
	On Land: Approx. 1,877 g Underwater: Approx. 546 g
STANDARD ACCESSORIES	Detachable & Foldable Monitor Hood x 1pc.
	Removable Power Bank (22.5W, 10,000mAh) x 1pc.
	Vacuum Hand Pump x 1pc.
	Spare Main Seal O-ring x 1pc.
	Spare O-ring for Vacuum Valve Protection Cap x 1pc.
	Silicone Grease x 1pc.
	Moisture Muncher Capsules™ x 1pc.
USB Type-C Charging Cable	

AOI is a registered trademark of AOI Ltd. All rights reserved.
GoPro is a trademarks for GoPro



www.aoi-uw.com

Made in China

6E011520-00001